

SETUP

1. **Back the pump pressure regulator completely off (counterclockwise) and close the ball valve.**
Attach the main air supply hose to ball valve on the pump fluid pressure regulator.
2. Attach fluid hose (BLUE HOSE) at pump outlet and gun fluid inlet.
3. Attach gun air hose (RED HOSE) to ball valve at gun pressure regulator and to air inlet on gun.
ball valve should be closed and regulator backed off.
4. Attach siphon hose to the pump inlet and insert siphon hose strainer into material to be sprayed.

BE SURE ALL CONNECTIONS ARE TIGHT

OPERATION

1. Remove air cap and fluid tip from spray gun.
2. Turn pump fluid pressure ball valve on and **slowly increase pressure on regulator** until pump begins to stroke.
3. Direct spray gun discharge into material container. Trigger the spray gun and hold open until fluid is flowing from gun. Release the spray gun trigger and pump will stop. Pump is now primed.
4. Replace the fluid tip and air cap on spray gun.
5. With the spray gun triggered, increase pressure on pump until a fan pattern appears at the spray tip.
6. Open the ball valve at the gun pressure regulator. Increase the atomizing air pressure to the gun until the spray pattern is even and no longer has tails.

NOTE: For HVLP compliance, maximum pressure setting on gun regulator is 15 psi .

Pump pressure may be increased to eliminate tails in pattern.

7. It is recommended that a solvent compatible with the material being sprayed be used in the pump solvent cup. This will increase pump seal life and minimize down time.

SHUT DOWN

FOR SHORT TERM SHUT DOWN:

1. Close the pump pressure ball valve and relieve pressure by triggering the spray gun.

FOR LONGER TERM SHUT DOWN:

1. Remove air cap and fluid tip from spray gun and close ball valve on gun pressure regulator.
2. Remove siphon hose from material.
3. Back pump pressure regulator off completely.
4. With the spray gun triggered and directed into the material container, slowly increase pressure on pump until pump strokes slowly. Continue until all material is returned to container.
5. Immerse siphon hose in a clean compatible solvent. Circulate solvent thru system until completely clean.
6. Purge solvent from system by removing siphon hose from solvent and continuing to operate pump until system is empty. Stop pump with pump rod in down position.

HAZARD WARNINGS

General safety

The C14 AAA system is intended to be used by professional personnel only. Everyone using this equipment should read and understand all safety warnings.

Do not exceed the maximum working pressure of this equipment. **MAXIMUM WORKING PRESSURE IS 1500 PSI FLUID PRESSURE (107 psi to air motor).**

Do not modify this equipment.

Always relieve fluid pressure to 0 psi before performing maintenance.

Make sure all fluid connections are tight before operating this equipment

Operate this equipment only in a well ventilated area to prevent build up of toxic and or flammable fumes.

Fluid injection hazard

High fluid pressure can cause serious injury if injected into skin.

NEVER aim the spray gun at part of the body or at anyone.

NEVER put a hand or fingers on or near a leaking hose, hose connection or the gun spray tip.

ALWAYS use gun fluid shut off knob when not spraying.

IF FLUID INJECTION SHOULD OCCUR, IMMEDIATELY SEEK MEDICAL ATTENTION!

Toxic fume and fluid hazard

Inhalation of toxic fumes and skin exposure to some chemicals can be a serious health hazard.

Read all manufactureres information for the material being sprayed, including material safety data sheets (MSDS sheets) and warnings.

Be sure recommended protective clothing and eye protection are used.

Wear a respirator or particle mask appropriate for material being sprayed.

Store all materials and solvents in accordance with manufacturers recommendations and local, and state safety codes.

Possible fire or explosion Hazard

Static sparks can cause fire or explosion.

The C14 AAA system is equipped with a grounding wire. Connect this wire to an appropriate earth ground source. Also ground objects being sprayed.

DO NOT operate this equipment near pilot lights, open flames or anyone smoking.

Keep spray area clear and free of combustibile debris.

C14 AAA system Components

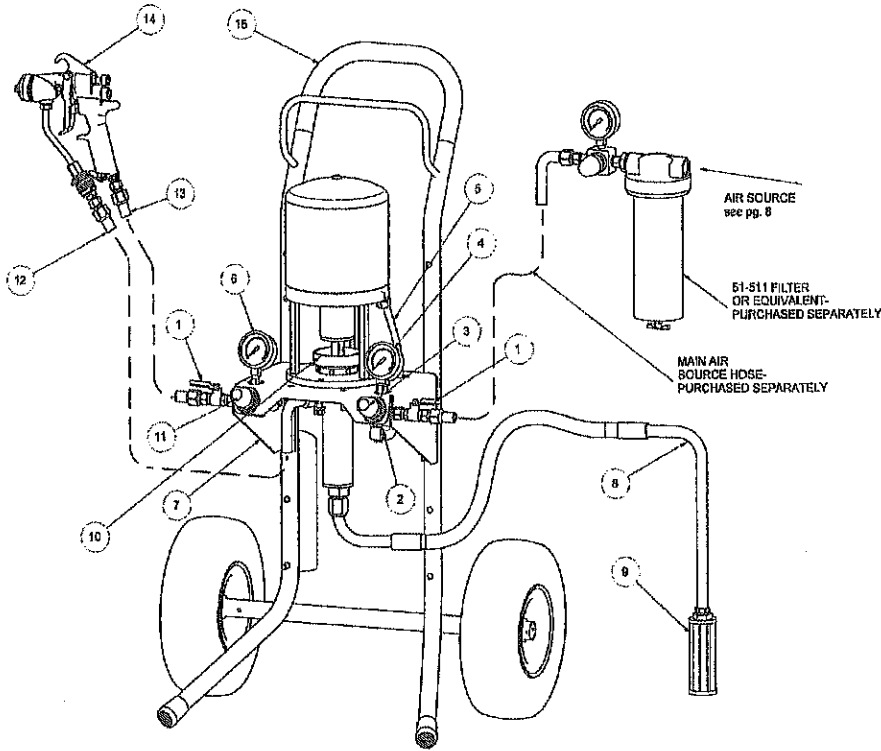

Fluid tip selection chart

Std. Tip #	Opti-Tip #	Orifice Size	Fan Width*
36-207	36-207-F	.007	4"
36-309	36-309-F	.009	6"
36-409	36-409-F	.09	8"
36-211	36-211-F	.011	4"
36-311	36-311-F	.011	6"
36-411	36-411-F	.011	8"
36-511	36-511-F	.011	10"
36-611	36-611-F	.011	12"
36-213	36-213-F	.013	4"
36-313	36-313-F	0.13	6"
36-413	36-413-F	.013	8"
36-513	36-513-F	.013	10"
36-613	36-613-F	.013	12"
36-315	N/A	.015	6"
36-415	N/A	.015	8"
36-515	N/A	.015	10"
36-615	N/A	.015	12"
36-715	N/A	.015	14"
36-815	N/A	.015	16"
36-417	N/A	.017	8"
36-517	N/A	.017	10"
36-717	N/A	.017	14"
36-619	N/A	.019	12"
36-719	N/A	.019	14"
36-621	N/A	.021"	12"

ITEM NO.	PART NO.	DESCRIPTION
1	52-150	Ball valve 1/4"
2	75-138	Interconnect tube assembly
3	75-151	Regulator assembly, air motor
4	52-58	Pressure gage, air motor 0-100 psi
5	75-146	Pump protector tube assembly
6	52-60	Pressure gage, gun air 0-30 psi
7	70-171	Pump mounting bracket
8	74-538	Siphon hose assembly 5 gal. (standard) 3/8" low volume
	74-521*	Siphon hose assembly 55 gal. (optional)
	74-520*	Siphon hose assembly 5 gal. (optional) 1/2" higher volume
9	74-561	Siphon hose strainer 60 mesh 3/8" (standard)
	74-562	Siphon hose strainer 60 mesh 1/2" (standard)
10	70-1410	Pump assembly (includes air motor and pump)
11	75-152	Gun regulator assembly
12	53-402	Fluid hose assembly 25 ft. (BLUE HOSE)
13	53-111-25	Air hose assembly 25 ft. (RED HOSE)
14	66-100	Cougar gun (less air cap and fluid tip)
15	70-180	Cart assembly

NOTE: Fluid and air hoses (items 12 & 13) are wrapped together in a hose sleeve. Sleeve material may be purchased separately as P/N 91-51

*Fan width is based on 10" gun to target distance. Material viscosity will influence fan width.

**Opti-Tip is proven to help reduce micro-bubbles in primers and waterborne coatings and also provides optimized atomization of topcoats, primers and paints. Opti-Tips are available for orifice sizes .007 thru .013. Order P/N 36-XXX-F Opti-Tip.

* Siphon hoses 74-520 and 74-521 require 1/2" fluid inlet (P/N 74-118)

C14 AAA Fluid section 74-101

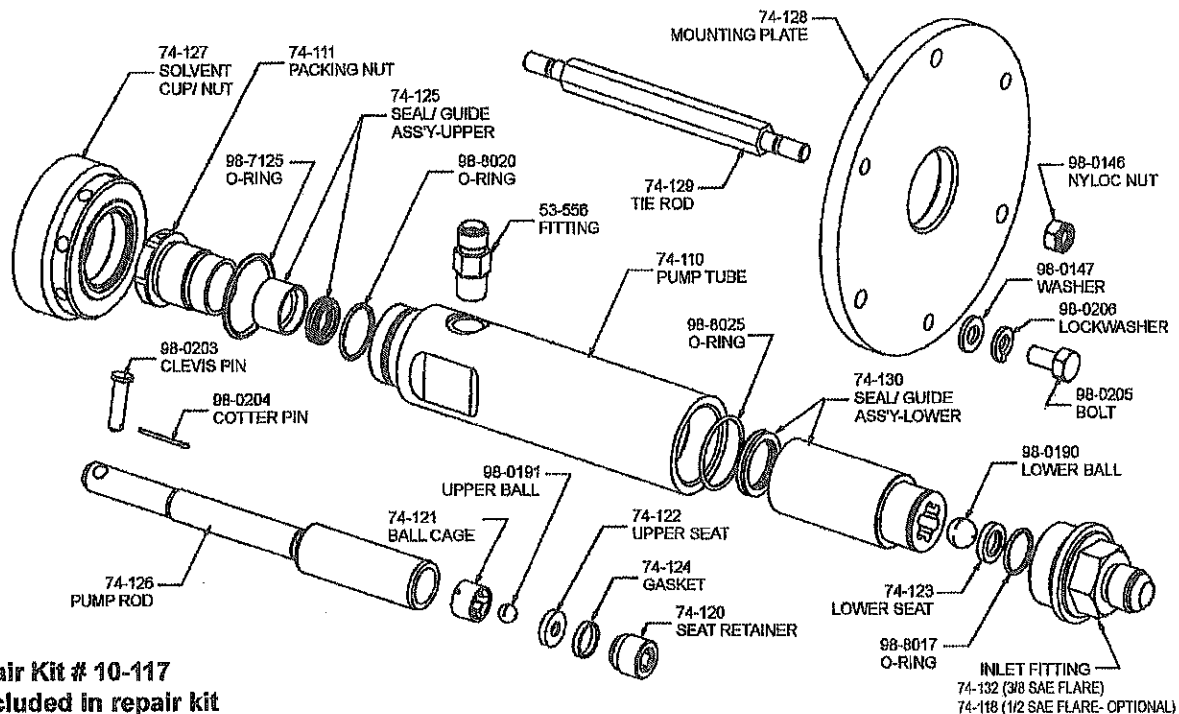

Repair Kit # 10-117
***Included in repair kit**

Disassembly from air motor

Pump disassembly and service is easiest if first removed from air motor

1. Disconnect the fluid hose and siphon hose from the pump.
2. Remove the cotter pin and clevis pin connecting the pump and air motor.
3. Leave mounting plate and tie rods attached to the air motor. Loosen and remove the solvent cup using the 1/4" pin wrench provided.

Pump disassembly

It is recommended that repair kit #10-117 be on hand before starting pump repair.

1. Holding the pump tube by the flats, remove the inlet fitting using an adjustable or 1 1/8" wrench. The lower ball and seat can be removed.
2. Push down on the pump rod from top of pump. The pump rod and lower seal/guide assembly will come out thru bottom of pump.
3. Remove the upper packing nut using an adjustable or 1 1/8" wrench. The upper seal/guide will come out with the upper packing nut.
4. Place one end of the 1/4" pin wrench thru the clevis pin hole in the pump rod. Using a 3/8" hex wrench remove the upper seat retainer. The upper seat, ball, and ball cage can be removed.

Pump reassembly

1. Inspect the pump rod in the areas where the upper and lower seals ride. If the diameter of the rod in these areas appear to be reduced or if scoring has occurred, the rod must be replaced. Replace the upper ball and seat into the rod using a new ball and seal. Note, the seat is reversible.
2. Replace the upper seal/guide and o-ring (98-8020) in the upper packing nut. Place upper packing nut into pump tube and tighten.
3. Place the lower end of the pump rod into a new lower seal/guide assembly and new o-ring (98-8025). Carefully slide upper end of pump rod into pump tube and thru the upper seal/guide.
4. Place a new o-ring (98-8017) around the lower seat (Note, seat is reversible) and push into the recess in the inlet fitting. Set a new ball on the seat and tighten inlet fitting into the pump tube.
5. Replace o-ring (98-7125) on pump tube and slide pump thru mounting plate and solvent cup. Orient the outlet fitting as desired and tighten the solvent cup to secure pump. Reattach the pump to the air motor by replacing the clevis pin and cotter pin.

C14AAA Air motor 75-100

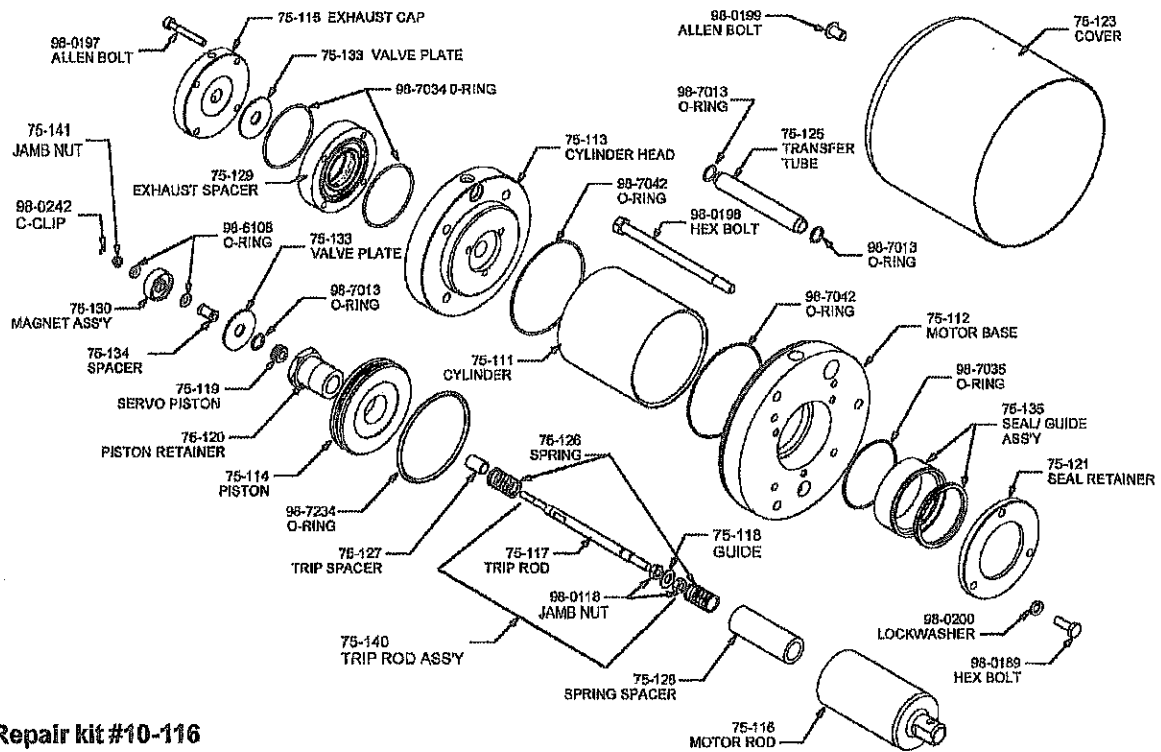

Repair kit #10-116

Replacing the air motor rod seal/guide assembly

The main air motor rod seal/guide assembly can be replaced without major disassembly of air motor.

1. Push the air motor rod up as high as possible.
2. Using a 7/16" wrench, remove the three hex head bolts and remove the seal retainer plate. The exposed end of the guide has a groove. Using two screw drivers, engage the groove and pry the seal/guide assembly out.
3. Lubricate o-ring (98-7035) and the new seal/guide assembly with petroleum jelly. Insert over air motor rod and into gland cavity. **Caution! Use care not to damage seal lips.**
4. Replace the retainer plate and three retainer plate screws.

Complete air motor disassembly

It is recommended that repair kit # 10-116 be on hand before starting pump repair .

1. Remove the air motor cover using a 1/4" hex wrench
2. Remove the four Allen head bolt (98-0197).
3. Remove the exhaust cap, valve plate, and exhaust spacer.
4. Push the air motor rod to the up position. Lift up on locknut (98-0196) until a flat on the trip rod is exposed just outside the top cylinder head. Using a 1/4" open end wrench on the trip rod and a second 1/4" wrench on the locknut, remove the locknut.
5. Continue holding the trip rod and unscrew the magnet assembly. Remove the spacer and servo piston. Note: Wrap the magnet assembly in a clean paper towel as it will attract any nearby magnetic debris.
6. Using a 1/2" wrench, remove the four hex head bolt holding retaining the cylinder head. Remove the cylinder head, cylinder and transfer tube.
7. Push the air motor rod out of the motor base. Using a 5/8" open end wrench on the air motor rod and a 1 1/4" wrench, remove the piston retainer. The trip rod and trip springs can be removed for inspection.
8. See instructions above for removal and replacement of the seal/guide assembly in the motor base.
9. Reassemble air motor in reverse order. Lubricate all o-rings using petroleum jelly during reassembly.